

VIEW OF FINISHED GOOD

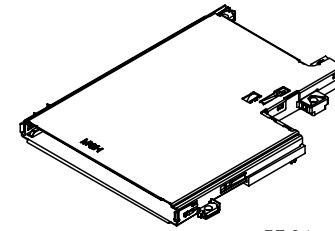

P/N	DESCRIPTION
47150-0003	W/O BOTTOM SHELL
47150-0004	W BOTTOM SHELL

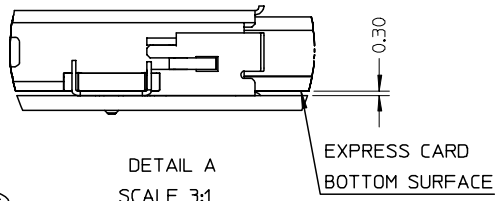
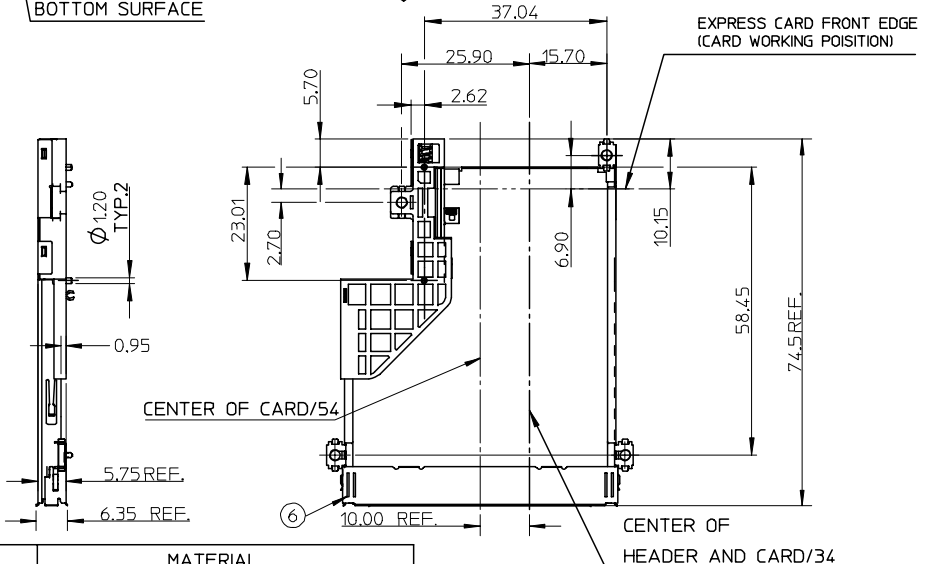
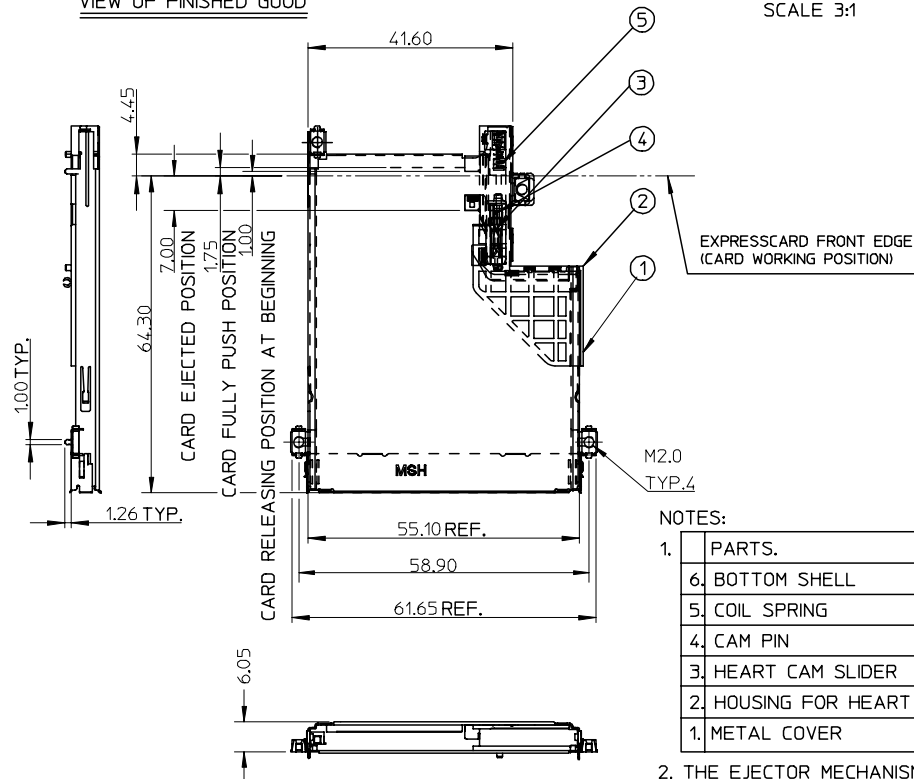

NOTES:

1.	PARTS.	MATERIAL
6.	BOTTOM SHELL	STAINLESS STEEL
5.	COIL SPRING	PIANO WIRE
4.	CAM PIN	STAINLESS STEEL
3.	HEART CAM SLIDER	HIGH TEMPERATURE THERMOPLASTIC
2.	HOUSING FOR HEART CAM	HIGH TEMPERATURE THERMOPLASTIC
1.	METAL COVER	STAINLESS STEEL

- 2. THE EJECTOR MECHANISM TO BE ASSEMBLED BASES ON 34 CARD CENTER LINE.
- 3. PRODUCT SPEC. REFERS TO PS-47202-001

- 4. APPLICABLE HEADER: 47150-0002
- 5. WHEN DELIVERING, THE HEART CAM SLIDER IS IN THE STATE OF THE SPRING RELEASED. (CARD EJECTED OUT POSITION).
- 6. SLOT DESIGN BASED ON EXPRESS CARD ASSOC. REV.A.
- 7. EXPRESSCARD SLOT TO BE COMPATIBLE BOTH EXPRESSCARD/34 AND /54.

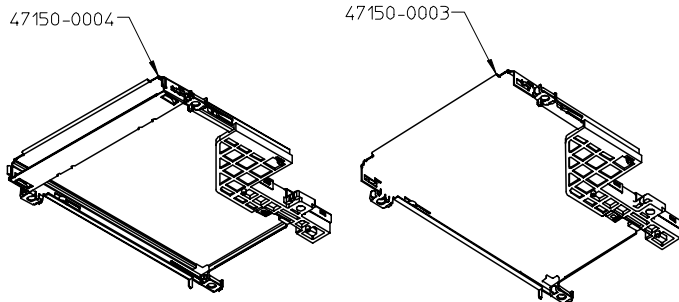

<p>NEW RELEASE</p> <p>EC NO: SH2006-0040</p> <p>DRWN: LBAO 2005/07/25</p> <p>CHKD: 2005/07/26</p> <p>APPR: YTYAP 2005/07/26</p>	<p>QUALITY SYMBOLS</p> <p>▽=0</p> <p>∇=0</p>	<p>GENERAL TOLERANCES (UNLESS SPECIFIED)</p>		<p>DIMENSION STYLE</p> <p>MM ONLY</p>	<p>SCALE</p> <p>1:1</p>	<p>DESIGN UNITS</p> <p>METRIC</p>	<p>THIRD ANGLE PROJECTION</p>		
		<p>4 PLACES ± --- ± ---</p> <p>3 PLACES ± --- ± ---</p> <p>2 PLACES ± 0.25 ± ---</p> <p>1 PLACE ± 0.25 ± ---</p>	<p>mm</p> <p>INCH</p>	<p>DRAWN BY</p> <p>R. BIAN</p>	<p>DATE</p> <p>2004/11/24</p>	<p>TITLE</p> <p>EXPRESSCARD SLOT WITH PUSH-PUSH MECHANISM TOP MOUNT</p>			
		<p>ANGULAR ± 3 °</p>		<p>APPROVED BY</p>	<p>DATE</p>	<p>MOLEX MOLEX INCORPORATED</p>			
		<p>DRAFT WHERE APPLICABLE MUST REMAIN WITHIN DIMENSIONS</p>		<p>MATERIAL NO.</p> <p>SEE TABLE</p>	<p>DOCUMENT NO.</p> <p>SD-47150-001</p>	<p>SHEET NO.</p> <p>1 OF 4</p>			

10 9 8 7 6 5 4 3 2 1

F

E

D

C

B

A

F

E

D

C

B

A

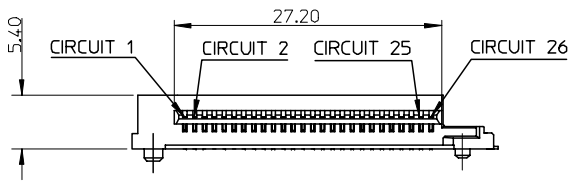
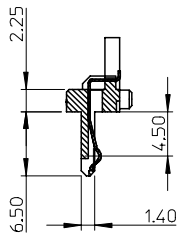
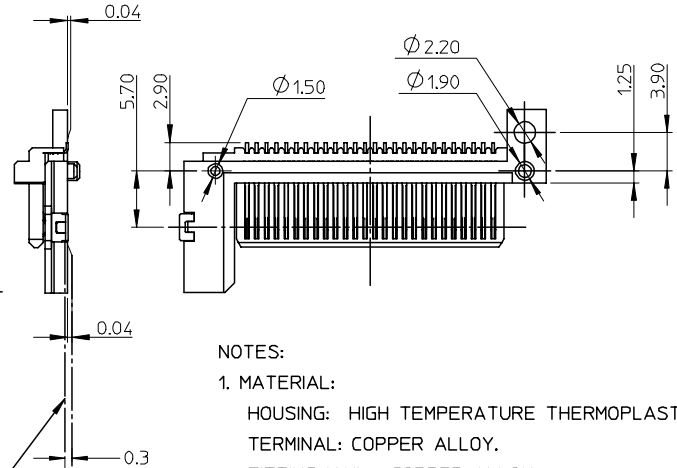
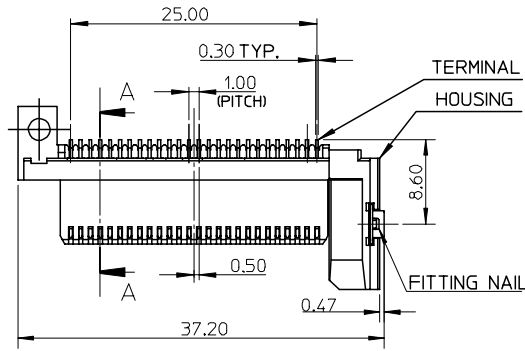
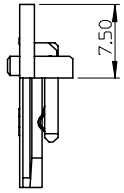
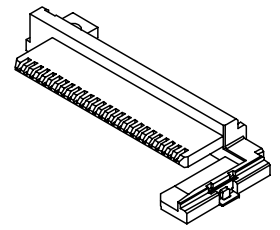
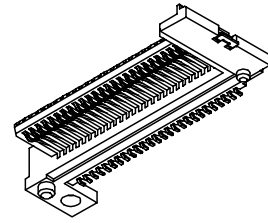

EXPRESS CARD
BOTTOM SURFACE

NOTES:

1. MATERIAL:

HOUSING: HIGH TEMPERATURE THERMOPLASTIC
TERMINAL: COPPER ALLOY.
FITTING NAIL : COPPER ALLOY.

2. FINISH:

TERMINAL: SELECTIVE GOLD(AU) IN CONTACT AREA.
THICKNESS: 0.3 MICROMETER MIN
SELECTIVE PURE TIN IN SOLDER TAIL AREA.
THICKNESS: 3 MICROMETER MIN
UNDERPLATING : NICKEL(NI) OVERALL

3.COPLANARITY AT SOLDER TAIL TO BE 0.1mm MAX.

4.PRODUCT SPEC. REFERS TO PS-47202-001

5.APPLICABLE EXPRESS CARD SLOT: 47150-0003/47150-0004

SECTION A-A

NEW RELEASE	2005/07/25
EC NO: SH2006-0040	2005/07/26
DRWN: LBAO	2005/07/26
CHKD:	2005/07/26
APPR: YTYAP	2005/07/26

QUALITY SYMBOLS	DESCRIPTION
▽=0	
∇=0	

GENERAL TOLERANCES (UNLESS SPECIFIED)	
	MM ONLY
4 PLACES	± 0.15
3 PLACES	± 0.20
2 PLACES	± 0.25
1 PLACE	± 0.30
ANGULAR ± 3 °	
DRAFT WHERE APPLICABLE MUST REMAIN WITHIN DIMENSIONS	

DIMENSION STYLE	
MM ONLY	
DRAWN BY	DATE
R. BIAN	2004/11/24
CHECKED BY	DATE
APPROVED BY	DATE
MATERIAL NO.	47150-0002

SCALE	DESIGN UNITS	THIRD ANGLE PROJECTION
2:1	METRIC	
TITLE		
EXPRESSCARD SLOT WITH PUSH-PUSH MECHANISM TOP MOUNT		
MOLEX INCORPORATED		
DOCUMENT NO.	SHEET NO.	
SD-47150-001	2 OF 4	
THIS DRAWING CONTAINS INFORMATION THAT IS PROPRIETARY TO MOLEX INCORPORATED AND SHOULD NOT BE USED WITHOUT WRITTEN PERMISSION		

9 8 7 6 5 4 3 2 1

10 9 8 7 6 5 4 3 2 1

F

E

D

C

B

A

F

E

D

C

B

A

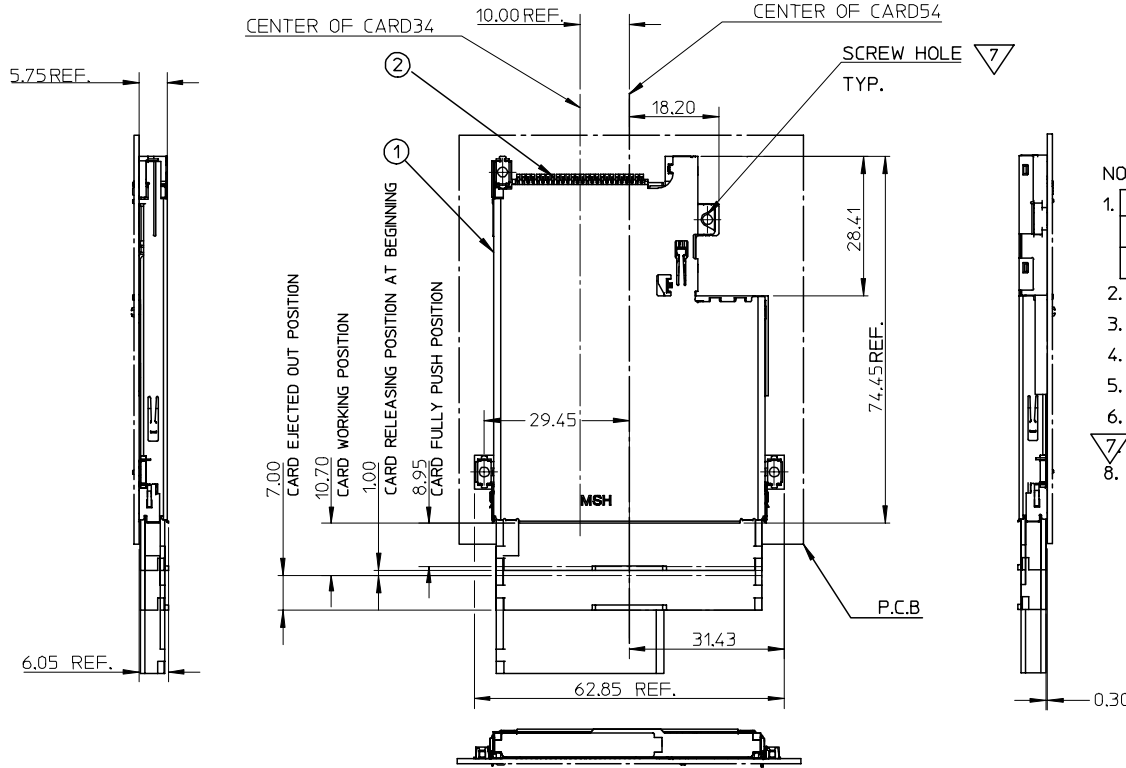
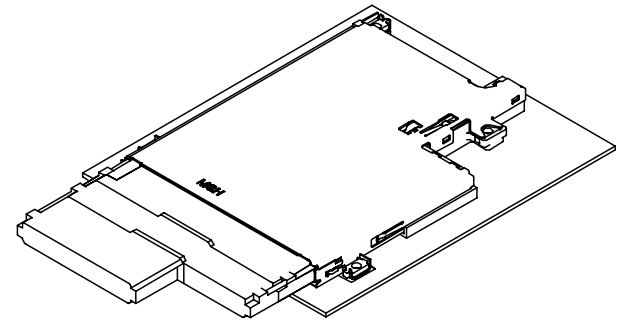
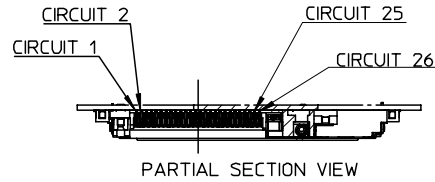

NOTES:

- | 1. NO. | DRAWING | MATERIAL NO. | DESCRIPTION |
|--------|-------------|-----------------------|-------------------|
| 1 | SEE SHEET 1 | 47150-0003/47150-0004 | EJECTOR MECHANISM |
| 2 | SEE SHEET 2 | 47150-0002 | CARD HEADER |
- P.C.B LAYOUT REFERS TO SHEET 4.
 - COPLANRTY OF HEADER FOR SMT SOLDER TAIL TO BE 0.1mm MAX
 - PRODUCT SPEC. REFERS TO PS-47202-001.
 - SCREW FASTENING TORQUE: 2kgf-cm.
 - TRUE POSITION IS 0.15mm MAX BETWEEN SOLDER TAILS.
 - 7 USING M2 SCREW AND NUT TO FIX
 - NON-REFLOW PROCESS FOR CARD SLOT

NEW RELEASE
 EC NO: SH2006-0040
 DRWN: LBAO 2005/07/25
 CHKD: 2005/07/26
 APPR: YIYAP 2005/07/26

QUALITY SYMBOLS
 ▽=0
 ◻=0

GENERAL TOLERANCES (UNLESS SPECIFIED)	
mm	INCH
4 PLACES ± ---	± ---
3 PLACES ± ---	± ---
2 PLACES ± 0.25	±
1 PLACE ± 0.25	±
ANGULAR ± 3 °	

DRAFT WHERE APPLICABLE
 MUST REMAIN WITHIN DIMENSIONS

DIMENSION STYLE MM ONLY	
DRAWN BY R. BIAN	DATE 2004/11/24
CHECKED BY	DATE
APPROVED BY	DATE
MATERIAL NO. N/A	DOCUMENT NO. SD-47150-001

SCALE 2:1	DESIGN UNITS METRIC	THIRD ANGLE PROJECTION
EXPRESSCARD SLOT WITH PUSH-PUSH MECHANISM TOP MOUNT		
molex MOLEX INCORPORATED		
SHEET NO. 3 OF 4		

9 8 7 6 5 4 3 2 1

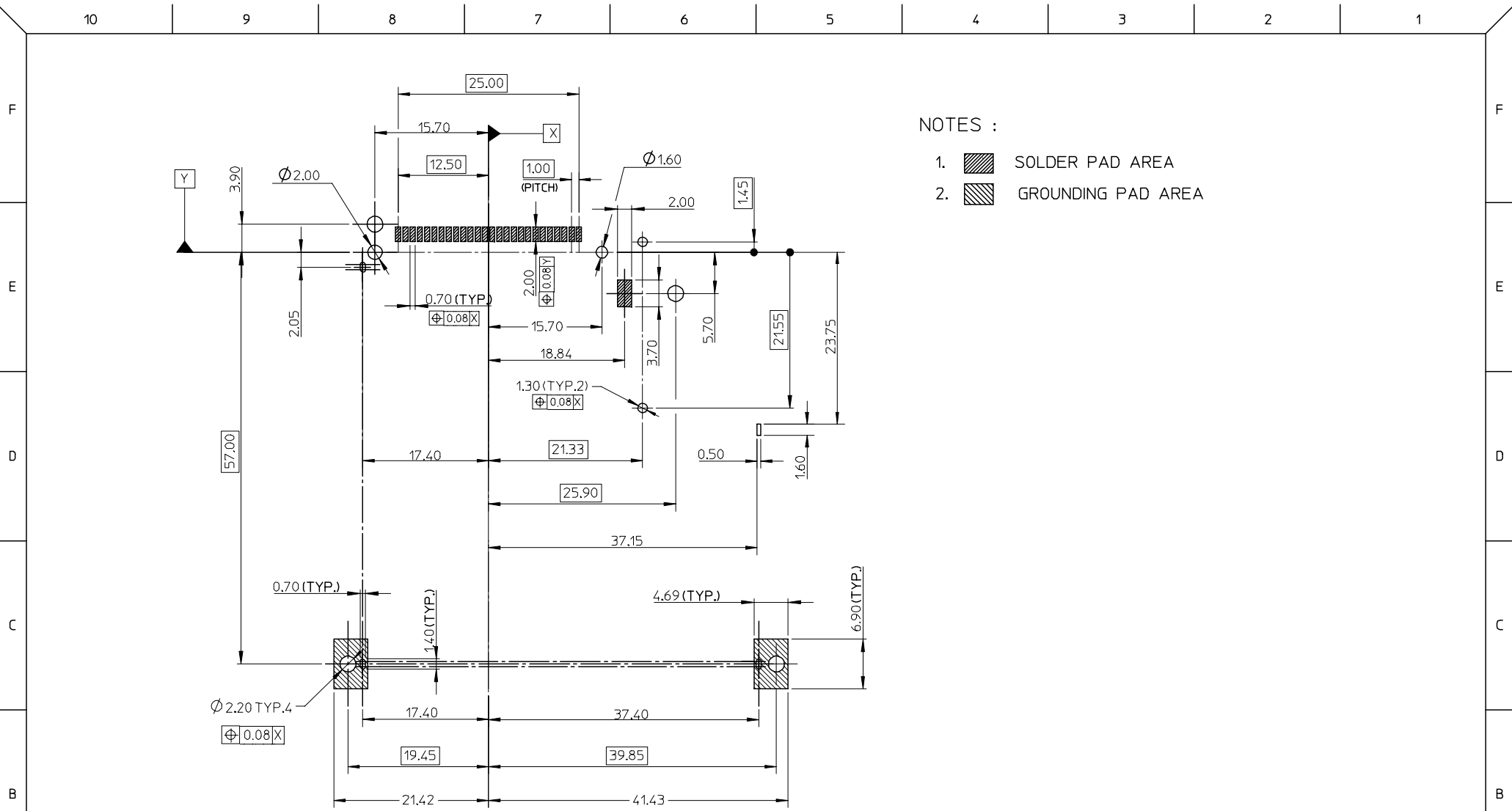

NOTES :

- 1. SOLDER PAD AREA
- 2. GROUNDING PAD AREA

NEW RELEASE EC NO: SH2006-0040 DRWN: LBAO CHKD: APPR: YIYAP	2005/07/25 2005/07/26 2005/07/26	DESCRIPTION REV	QUALITY SYMBOLS	GENERAL TOLERANCES (UNLESS SPECIFIED)	DIMENSION STYLE	SCALE	DESIGN UNITS	THIRD ANGLE PROJECTION															
			$\nabla = 0$ $\sphericalangle = 0$	<table border="1"> <thead> <tr> <th></th> <th>mm</th> <th>INCH</th> </tr> </thead> <tbody> <tr> <td>4 PLACES</td> <td>± ---</td> <td>± ---</td> </tr> <tr> <td>3 PLACES</td> <td>± ---</td> <td>± ---</td> </tr> <tr> <td>2 PLACES</td> <td>± 0.25</td> <td>±</td> </tr> <tr> <td>1 PLACE</td> <td>± 0.25</td> <td>±</td> </tr> </tbody> </table>		mm	INCH	4 PLACES	± ---	± ---	3 PLACES	± ---	± ---	2 PLACES	± 0.25	±	1 PLACE	± 0.25	±	MM ONLY	1:1	METRIC	
				mm	INCH																		
			4 PLACES	± ---	± ---																		
3 PLACES	± ---	± ---																					
2 PLACES	± 0.25	±																					
1 PLACE	± 0.25	±																					
		<table border="1"> <tr> <td>DRAWN BY</td> <td>DATE</td> <td>TITLE</td> </tr> <tr> <td>R. BIAN</td> <td>2004/11/24</td> <td>EXPRESSCARD SLOT WITH PUSH-PUSH MECHANISM TOP MOUNT</td> </tr> <tr> <td>CHECKED BY</td> <td>DATE</td> <td></td> </tr> <tr> <td>APPROVED BY</td> <td>DATE</td> <td></td> </tr> </table>	DRAWN BY	DATE	TITLE	R. BIAN	2004/11/24	EXPRESSCARD SLOT WITH PUSH-PUSH MECHANISM TOP MOUNT	CHECKED BY	DATE		APPROVED BY	DATE				MOLEX INCORPORATED						
DRAWN BY	DATE	TITLE																					
R. BIAN	2004/11/24	EXPRESSCARD SLOT WITH PUSH-PUSH MECHANISM TOP MOUNT																					
CHECKED BY	DATE																						
APPROVED BY	DATE																						
			DRAFT WHERE APPLICABLE MUST REMAIN WITHIN DIMENSIONS	MATERIAL NO. N/A	DOCUMENT NO. SD-47150-001	SHEET NO. 4 OF 4																	